

S:\AFMMACHINES\23000 XYR\23002 8 X 8\

ITEM NO.	PART NUMBER	PartNo	DESCRIPTION	QTY.
1	23002-002	101053	Y-Plate (8x12XYR)	1
2	23002-001	101052	Base Plate (8x12 XYR)	1
3	23002-003	101054	X-Plate (8x12 XYR)	1
4	250 Hardend Washer		.250 Hardened Washer	10
5	.250 X .750		.250 X .750 Dowel Pin	1
6	23001-003	104674	SLIDE PLATE	2
7	23002-004	101062	R-Plate (8x12 XYR)	1
8	23001-006	104677	ADJUST PLATE	2
9	23002-007	104678	R ADJUST PLATE	1

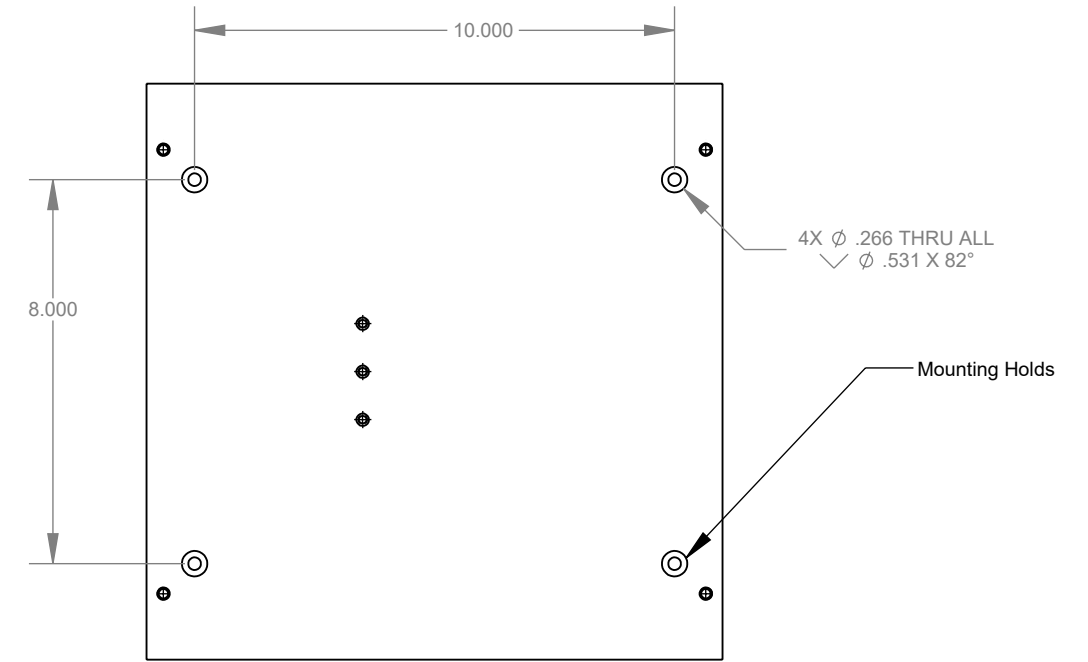
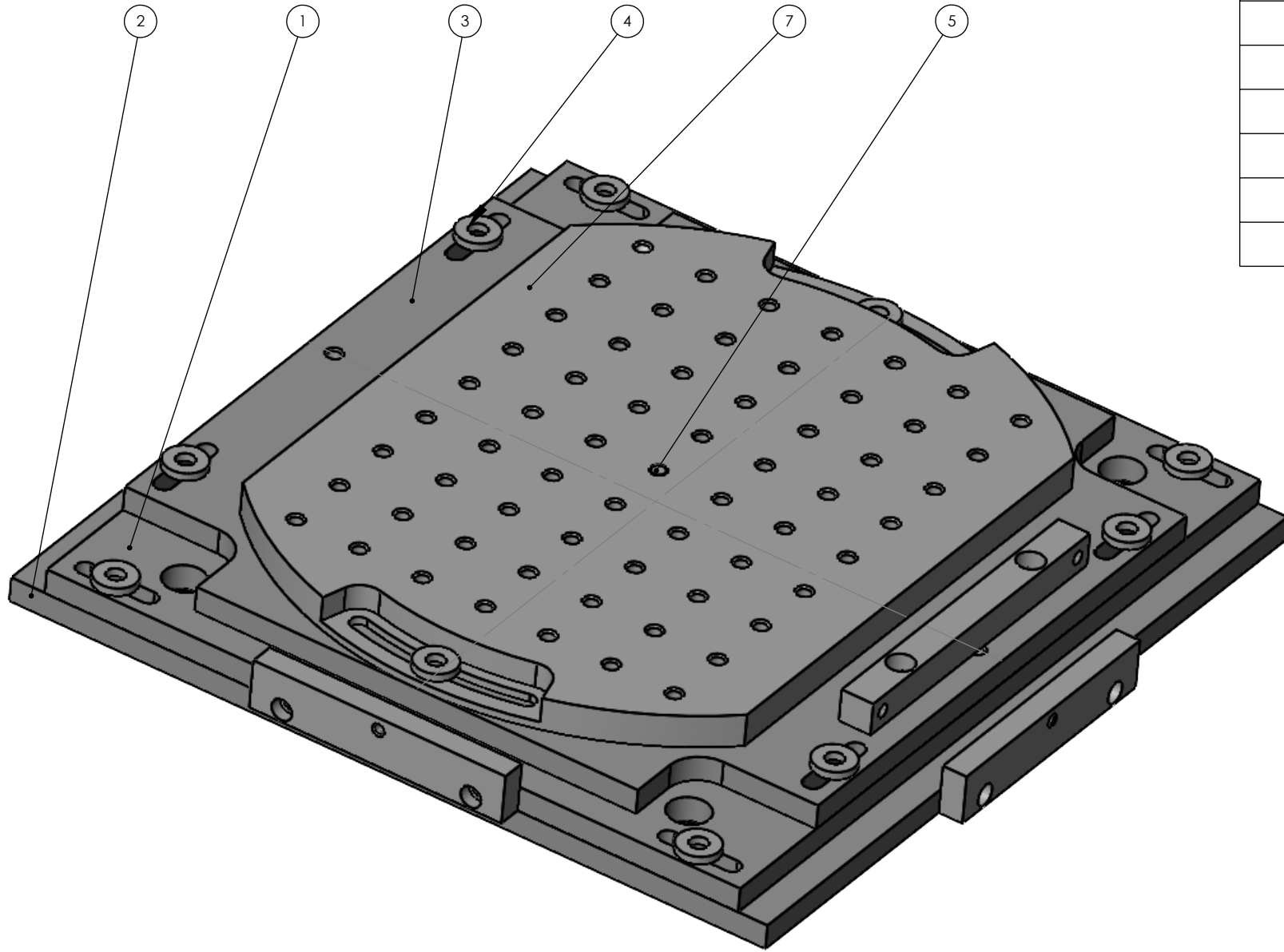

PROPRIETARY AND CONFIDENTIAL
 THE INFORMATION CONTAINED IN THIS DRAWING IS THE SOLE PROPERTY OF AFM ENGINEERING, INC. ANY REPRODUCTION IN PART OR AS A WHOLE WITHOUT THE WRITTEN PERMISSION OF AFM ENGINEERING INC. IS PROHIBITED.

DIMENSIONS ARE IN INCHES		NAME	DATE	
TOLERANCES:		DRAWN	Irwin	4/11/2005
FRACTIONAL \pm		CHECKED	Irwin	4/11/2005
ANGULAR: MACH \pm BEND \pm		ENG APPR.		
TWO PLACE DECIMAL \pm .010		MFG APPR.		
THREE PLACE DECIMAL \pm .005		Q.A.		
MATERIAL		COMMENTS:		
NEXT ASSY	USED ON	FINISH		
APPLICATION		DO NOT SCALE DRAWING		

AFM Engineering, Inc.		
AFM Engineering Inc. XYR Location Table, 6x8 AFM PART # 105231		
SIZE	DWG. NO.	REV.
B	23002-000-RevB	
SCALE: 1:4	WEIGHT: 17.769	SHEET 1 OF 1