

REV	DATE	CHANGE	TR NO.	REV BY.

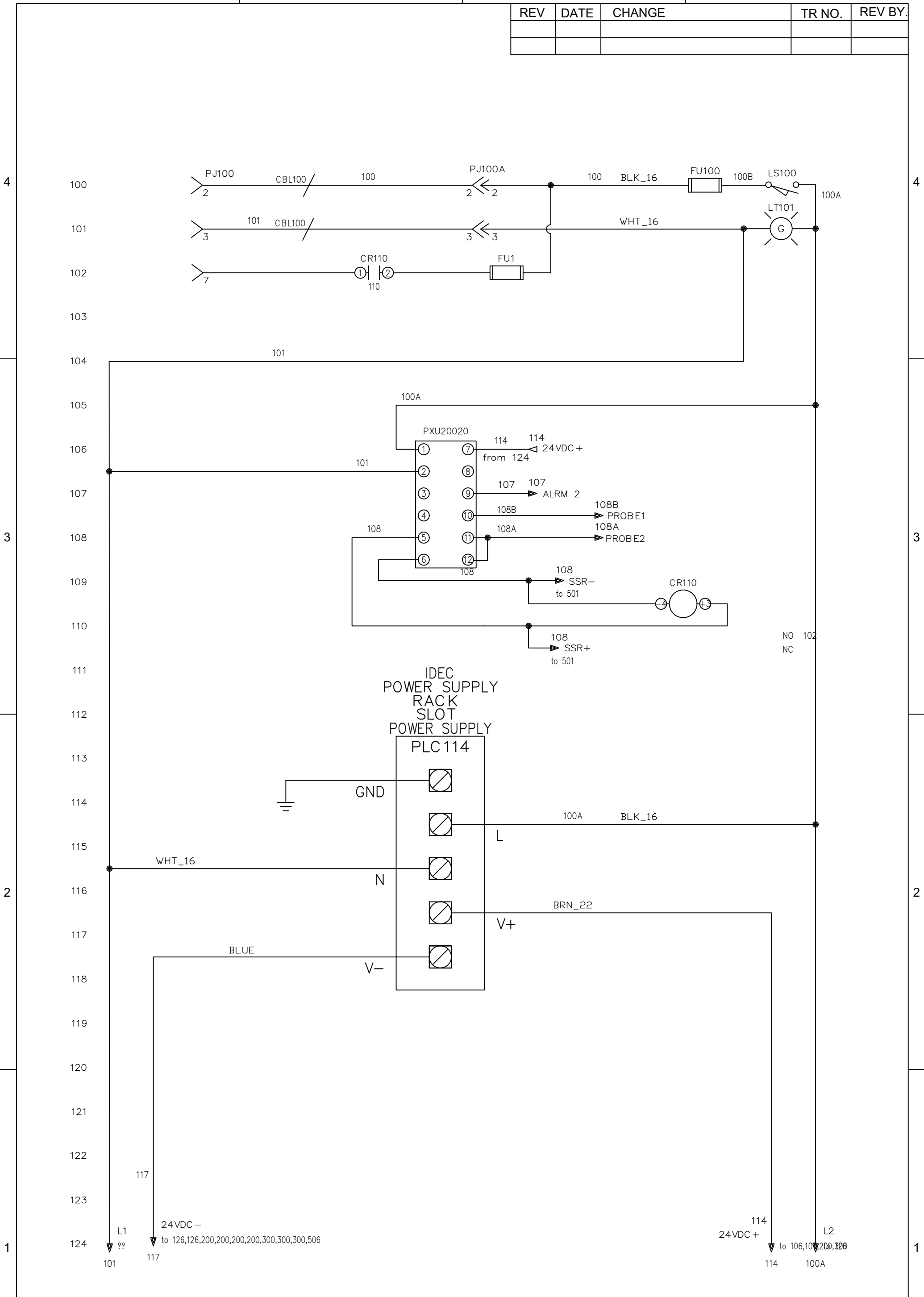

S:\AFMMachines\19000 Hot Stamp Control Box\19070_IDEC\19070_ Idec_FT1A-C12RA-S\100-1.dwg

AFM ENGINEERING, INC.
 1313 E. Borchard Ave
 Santa Ana, CA 92705

TITLE AFM ENGINEERING, INC.
 POWER INPUT
 19070_Idec PN 105208
 DRAWING NO. 100-1 SHEET 1 OF 5

DESIGNED BY C.S.I. 9/24/2023
 DRAWN BY C.S.I. 9/24/2023
 CHECKED BY C.S.I. 9/24/2023
 APPROVED BY C.S.I. 9/24/2023

REV	DATE	CHANGE	TR NO.	REV BY.

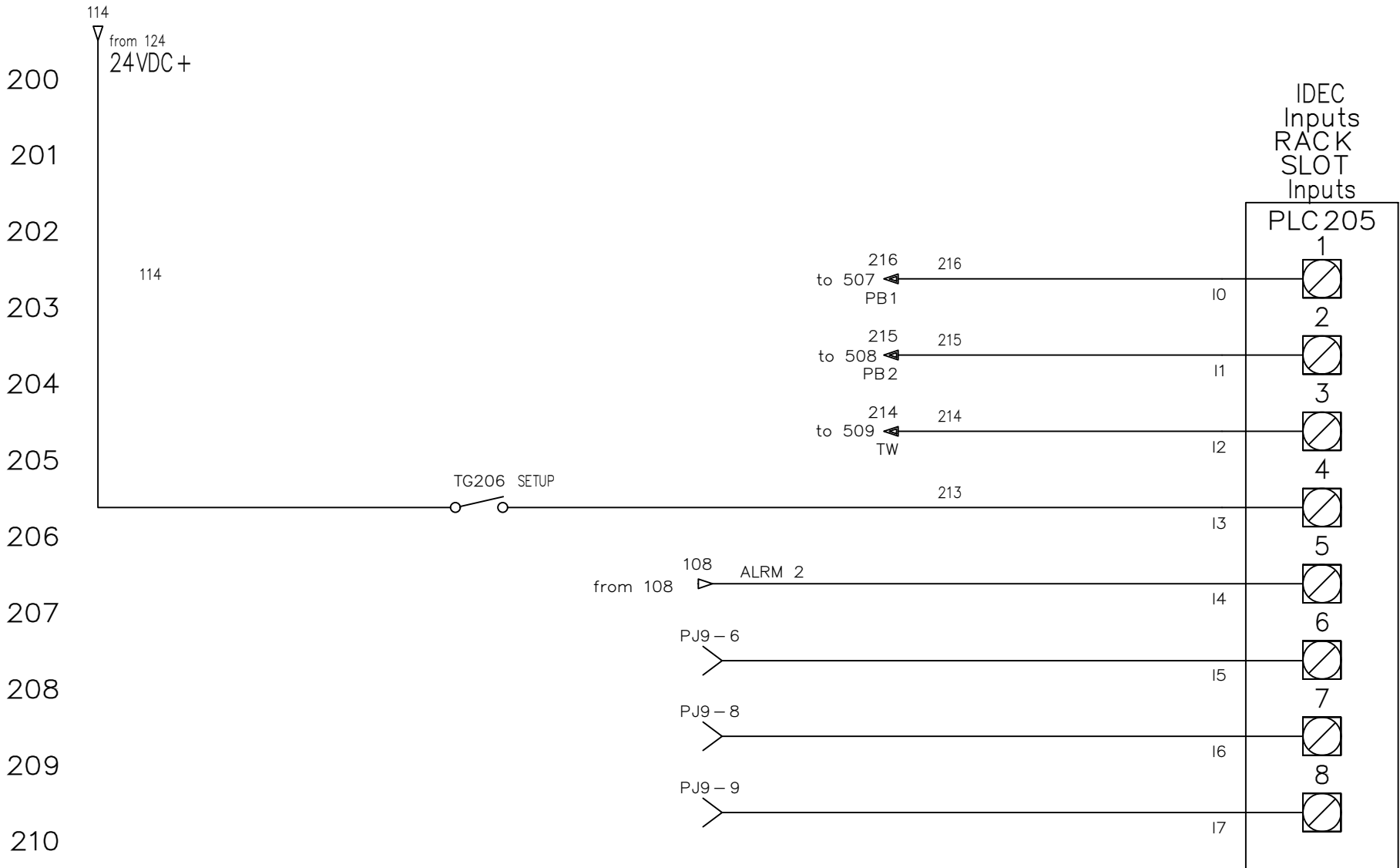

S:\AFMMachines\19000 Hot Stamp Control Box\19070_IDEC\19070_ Idec_FT1A-C12RA-S\200-1.dwg



1313 E. Borchard Ave
Santa Ana, CA 92705

TITLE AFM ENGINEERING, INC.
INPUTS
19070_Idec PN 105208

DRAWING NO. 200-1

SHEET 2 OF 5

DESIGNED BY C.S.I.	9/24/2023
DRAWN BY C.S.I.	9/24/2023
CHECKED BY C.S.I.	9/24/2023
APPROVED BY C.S.I.	9/24/2023

A

B

C

D

REV	DATE	CHANGE	TR NO.	REV BY.

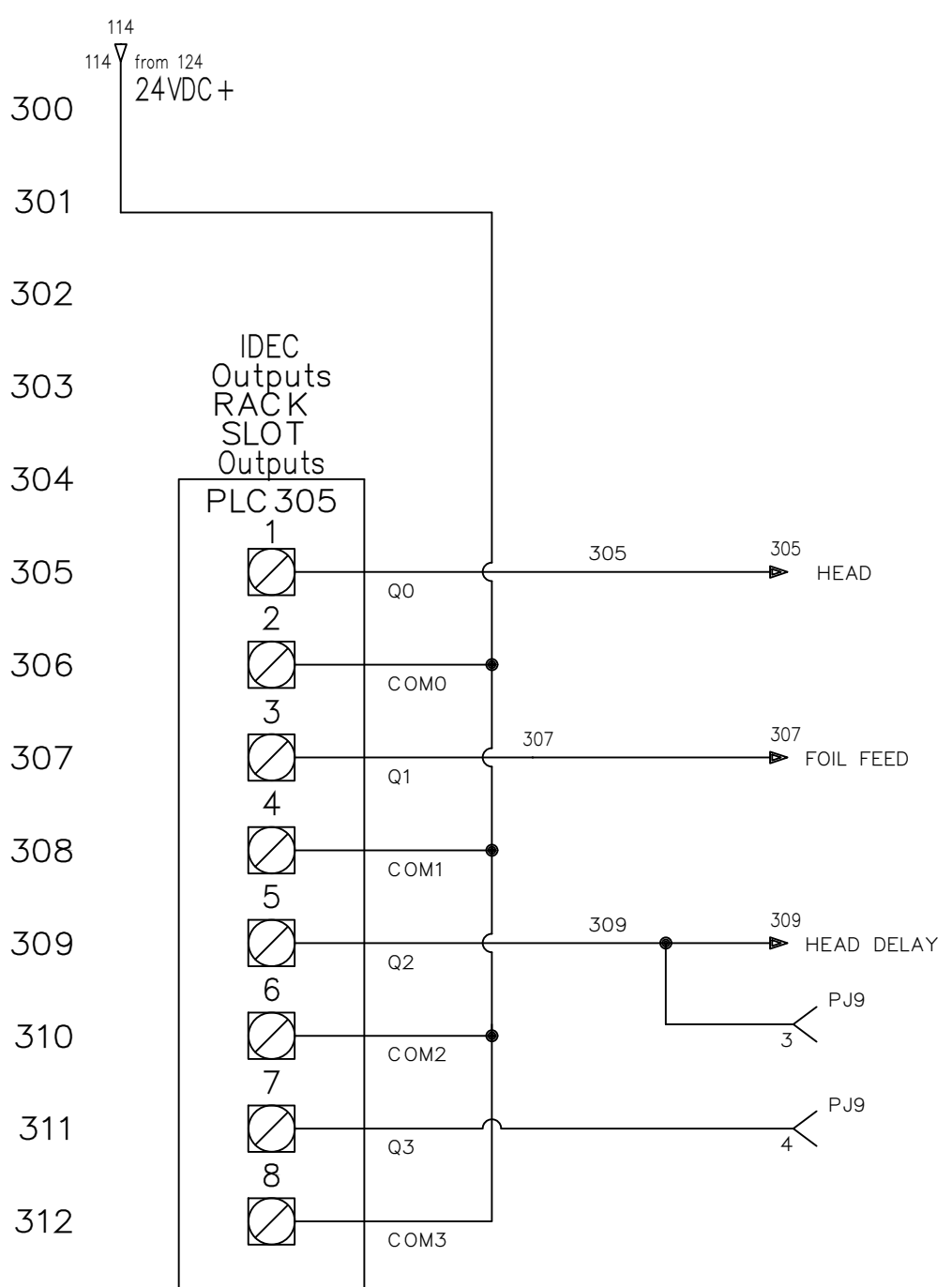

S:\AFMMachines\19000 Hot Stamp Control Box\19070_IDEC\19070_ Idec_FT1A-C12RA-S\300-1.dwg



TITLE AFM ENGINEERING, INC.
OUTPUTS
19070_Idec PN 105208

DRAWING NO. 300-1 SHEET 3 OF 5

DESIGNED BY C.S.I.	9/24/2023
DRAWN BY C.S.I.	9/24/2023
CHECKED BY C.S.I.	9/24/2023
APPROVED BY C.S.I.	9/24/2023

REV	DATE	CHANGE	TR NO.	REV BY.

CONTROL BOX BOARD AND CABLES REV7

4
3
2
1

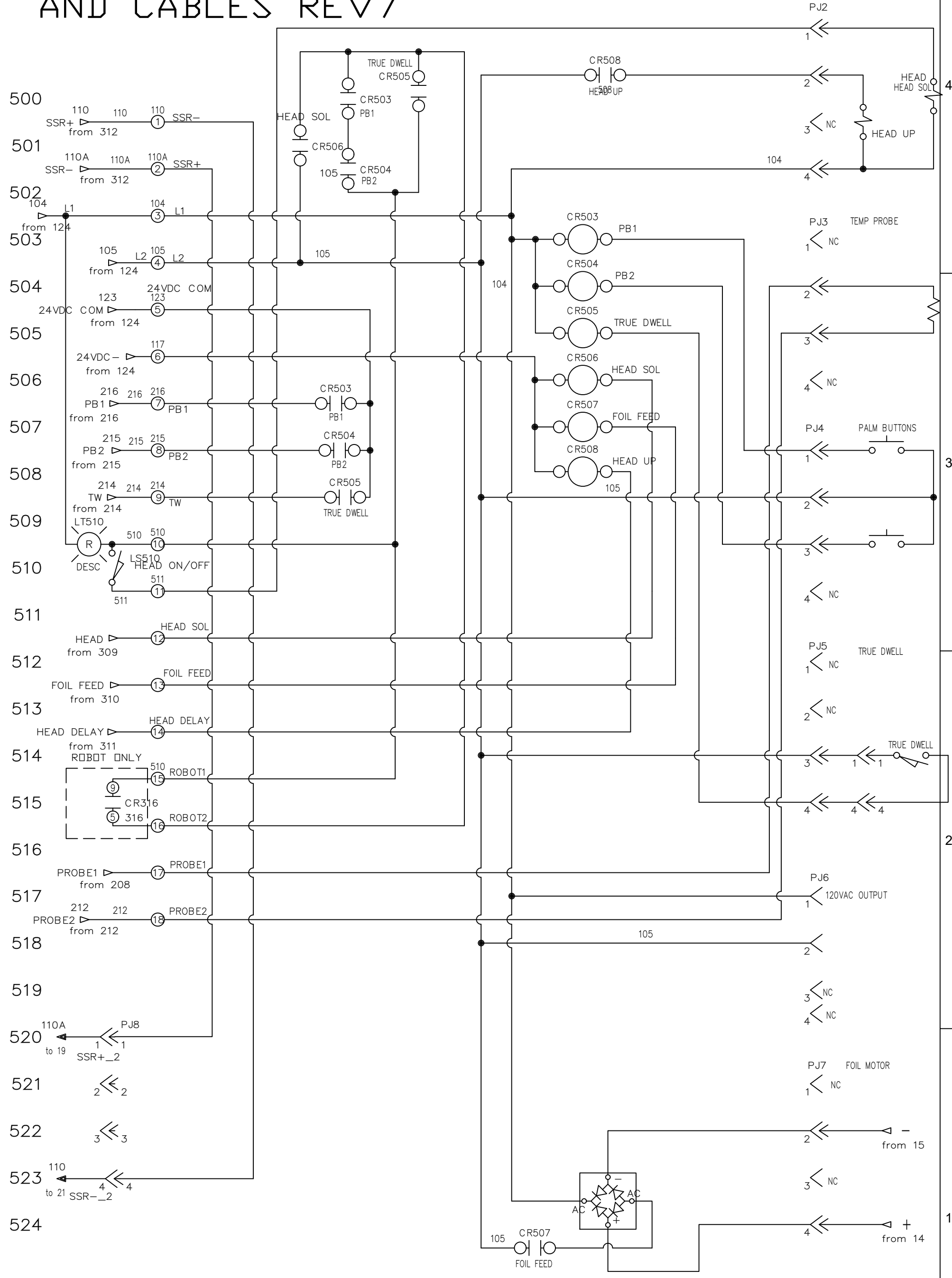

S:\AFMMachines\19000 Hot Stamp Control Box\19070_IDEC\19070_ Idec_FT1A-C12RA-S\500-1.dwg

AFM ENGINEERING, INC.
 1313 E. Borchard Ave
 Santa Ana, CA 92705

TITLE AFM ENGINEERING, INC.
 PC BOARD
 19070_Idec PN 105208
 DRAWING NO. 500-1 SHEET 4 OF 5

DESIGNED BY C.S.I. 9/24/2023
 DRAWN BY C.S.I. 9/24/2023
 CHECKED BY C.S.I. 9/24/2023
 APPROVED BY C.S.I. 9/24/2023

A B C D

REV	DATE	CHANGE	TR NO.	REV BY.

THIS SHEET USED ONLY IF 9 PIN INTERFACE PLUG IS USED

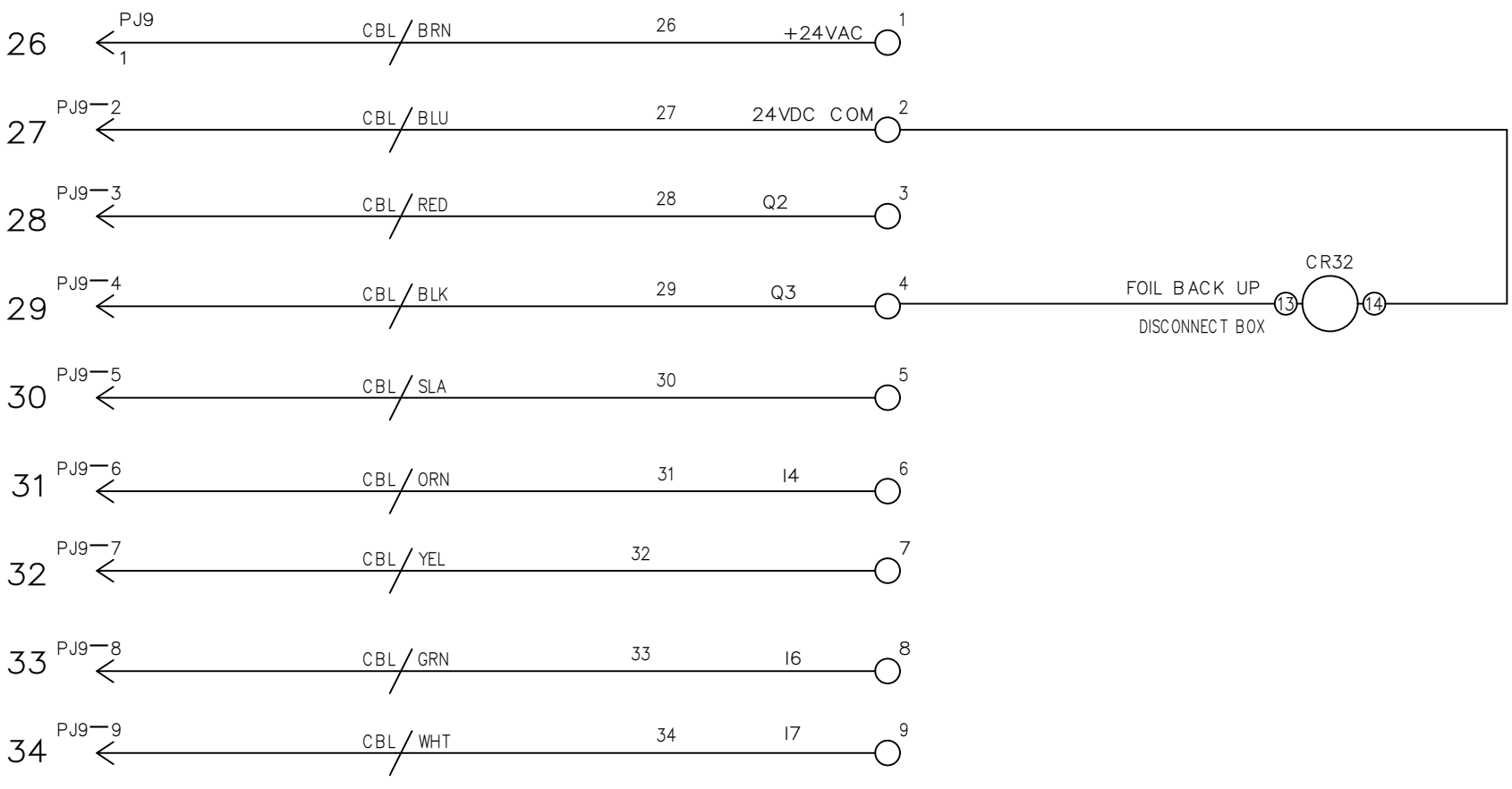

40,42
41,43

35
36
37
38
39
40
41
42
43
44
45
46
47
48
49
50

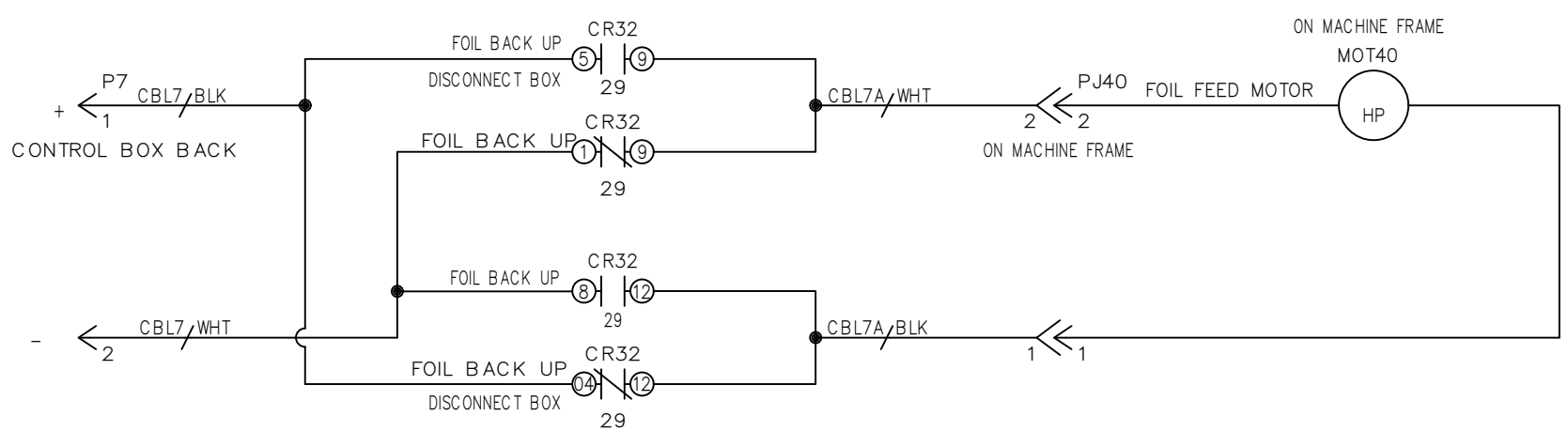

S:\AFMMachines\19000 Hot Stamp Control Box\19070_IDEC\19070_ Idec_FT1A-C12RA-S\600-1.dwg



TITLE AFM ENGINEERING, INC.
9 PIN CABLE
19070_Idec PN 105208
DRAWING NO. 600-1 SHEET 5 OF 5

DESIGNED BY C.S.I. 9/24/2023
DRAWN BY C.S.I. 9/24/2023
CHECKED BY C.S.I. 9/24/2023
APPROVED BY C.S.I. 9/24/2023

A B C D