

Palm Button Switches
 AFM Part# 103614
 YA-2RB-A2 Honeywell
 4 required

Switch Enclosure
 for BZ/BA Switch
 AFM Part# 100129
 5PA2 Honeywell
 4 required

3 PIN Male Plug
 AFM Part# 104871
 ML-3 Leviton
 1 required

Kensol NON OSHA Compliant Palm Button Assembly

REVISIONS

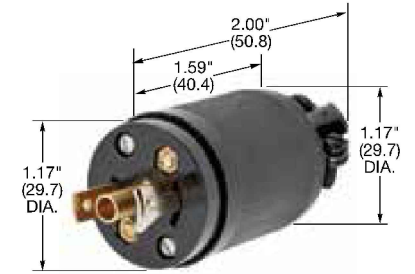

HBL7594

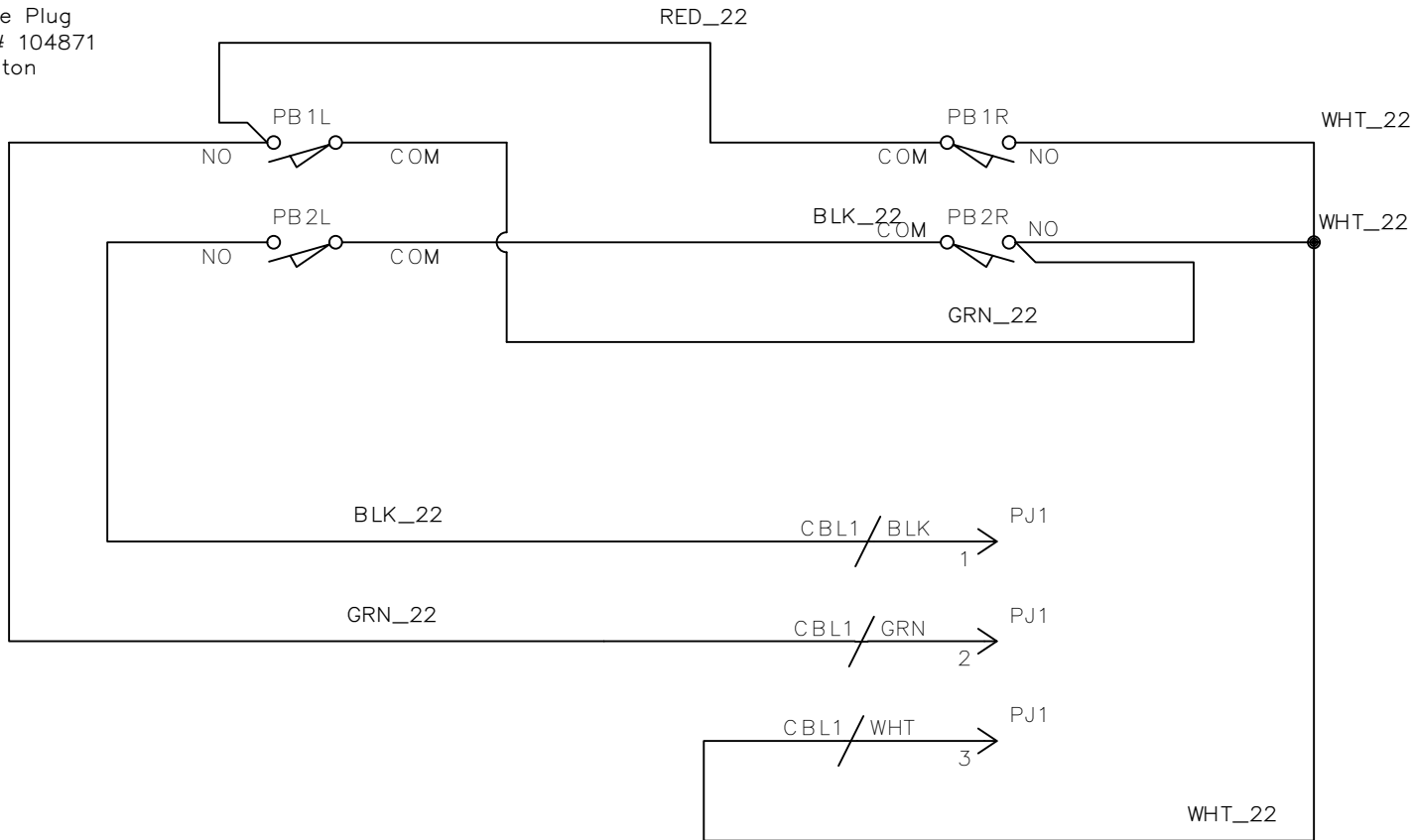
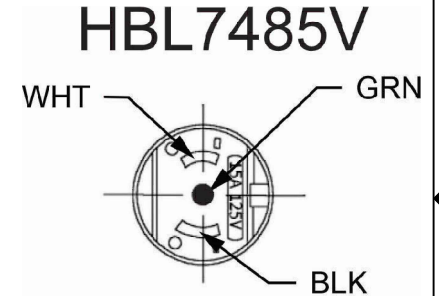

S:\AFMMachines\19201 Kensol Control\Kensol_Cabling\Kensol Machine Cable Wiring\100_Kensol_Cabling.dwg

AFM ENGINEERING, INC.
 1313 E. Borchard Ave
 Santa Ana, CA 92705

TITLE AFM Engineering, Inc.
 PALM BUTTON 4 SWITCH
 Kensol Cabling AFM PART NUMBER 105217

DESIGNED BY	C.S.I.
DRAWN BY	C.S.I.
CHECKED BY	C.S.I.
APPROVED BY	C.S.I.

DRAWING NO. 100_Kensol_Cabling SHEET 1 OF 2